

ZS01-M1

Weighing module for 10t...50t



Special features 特点

- Equipped with self-restoring rocker pin load cell CTA, class C2,C3 according to OIML R60
- Stay rod included in the scope of supply
- Designed for lift-off device
- Easy installation
- Two versions available: Galvanized material Stainless steel
- 用于精度等级为C2, C3的自复位柱式传感器CTA;
- 包括支撑杆
- 设计用于离地保护装置
- 安装简单
- 电镀材料和不锈钢可选。

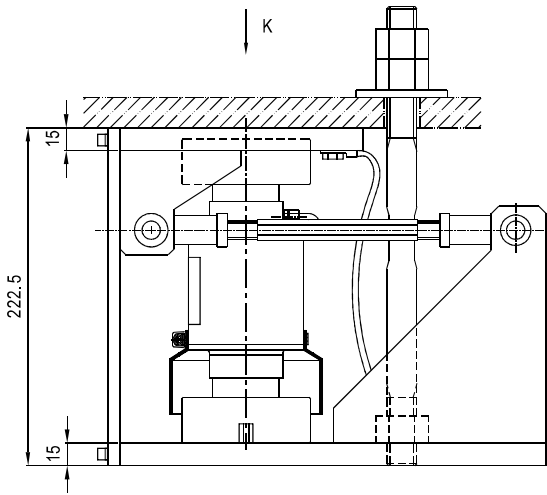

Top view, 顶视图, 无容器脚
drawing without tank foot

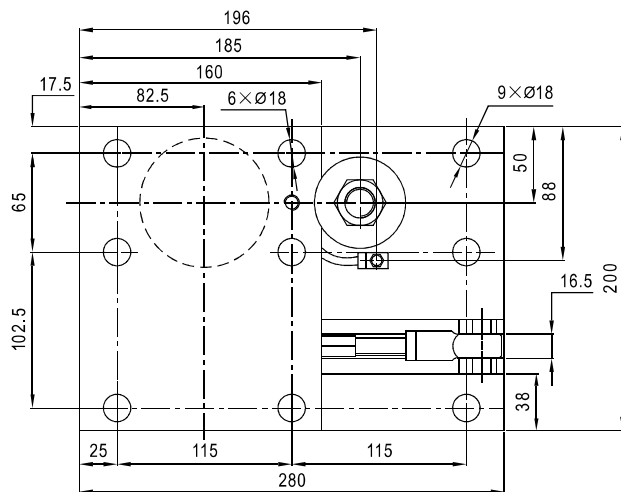

Specifications 技术说明 Exc+激励正 (Red,红);Exc-激励负(Black,黑);Sig+信号正(Green,绿);Sig-信号负(White,白)

Maximum capacity 额定载荷	t	10	20	25	30	40	50
Limit load 安全载荷	% of Maximum capacity	150%					
Restoring force (at 1mm side offset 回复力 vertically to the control arm direction)	% of Applied load	0.45	0.49	0.65	0.76	0.94	0.98
Maximum permissible side offset transverse to the control arm axis 控制臂方向最大允许水平位移	mm	4.0					
Maximum permissible horizontal force in the control arm direction 控制臂方向最大允许水平力	kN	50					
Max. permissible lifting force 最大允许升力, 用 (when a lift-off device is used)于离地保护装置	kN	80					
Material 材料:		Galvanized or stainless steel 电镀材料或不锈钢					
Weight(G),approx. 重量	kg	19					
Cable 电缆: Diameter 直径 Ø 6mm Length 长度	m	10	12	14	16		

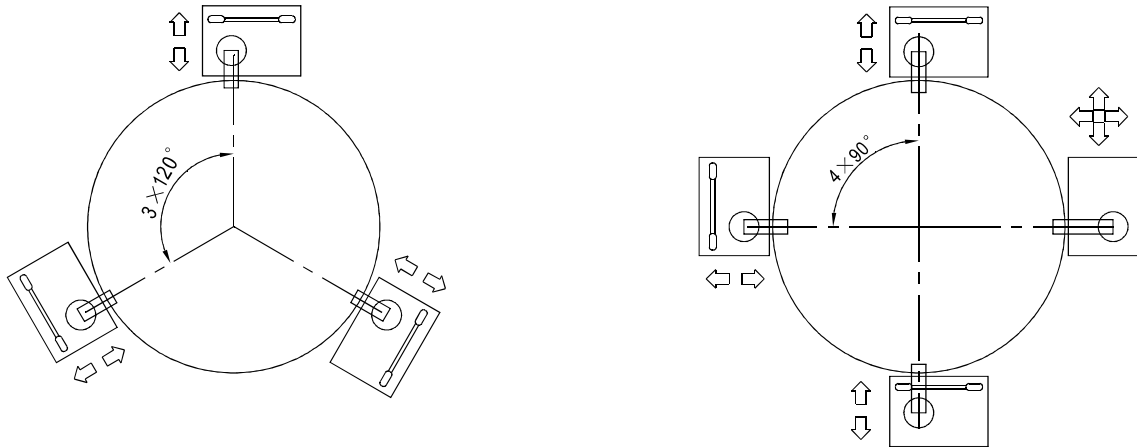

Mounting examples for weighing modules with stay rods: 带有支撑杆的称重模块安装示例

Cylindrical arrangement of the weighing module below tanks
称重模块在罐下部的圆形布置

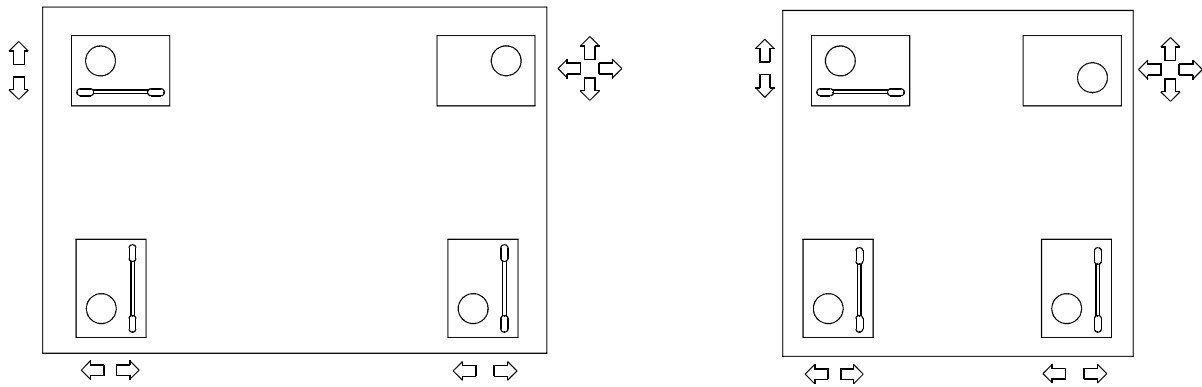

Rectangular arrangement of the weighing module below tanks
称重模块在罐下部的方形布置



Remark 备注:  Stay rod 支撑杆  Load introduction 负载方向  Degree of freedom 自由度

Further accessory: 其他附件

Fixed bearings with the same installation height as the weighing module.
固定底座与称重模块是同样的高度；安装时具有替代作用。

