

SB02 Load cells

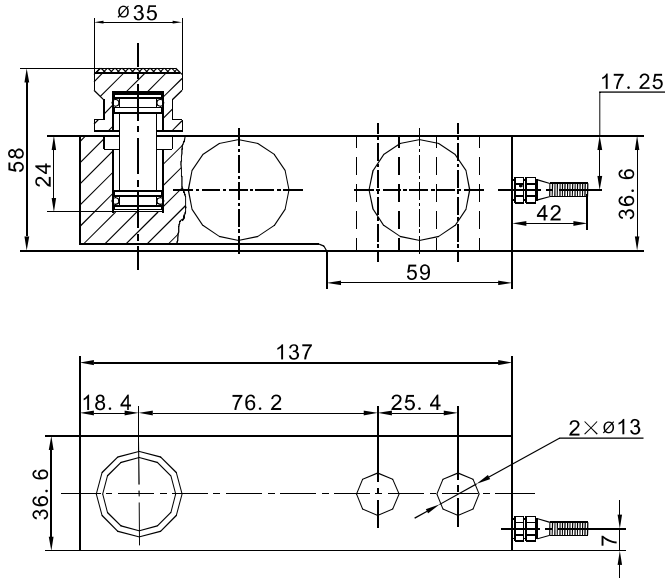

地上衡、配料秤、料斗秤、
平台秤
Floor scale, blending scale,
hopper scale, platform scale

Specifications 技术说明 Exc+激励正 (Red,红);Exc-激励负(Black,黑);Sig+信号正(Green,绿);Sig-信号负(White,白)

Item 项目	Unit 单位	Parameter 参数		
		C 2	C 3	
Accuracy class to OIMLR 60 精度等级		C 2	C 3	
Maximum capacity (E_{max}) 额定载荷	t	0.5,1,2		
Minimum LC verification interval (V _{min}) 最小检定分度值	% of E _{max}	0.0200		
Sensitivity (C_n) / Zero balance 灵敏度/零点平衡	mV/V	2.0 ± 0.002 / 0 ± 0.02		
Temperature effect on zero balance (TK ₀) 温度对零点影响	% of C _n /10K	± 0.02	± 0.0170	
Temperature effect on sensitivity (TK _c) 温度对灵敏度影响	% of C _n /10K	± 0.02	± 0.0170	
Hysteresis error (d _{hy}) 滞后误差	% of C _n	± 0.0330	± 0.0180	
Non-linearity(d _{lin}) 非线性误差	% of C _n	± 0.0250	± 0.0167	
Creep(d _{cr}) over 30 min. 蠕变及蠕变恢复	% of C _n	± 0.0233	± 0.0167	
Input (R_{Lc}) & Output resistance (R_o) 输入&输出电阻	Ω	400 ± 10 & 352 ± 3		
Nominal range of excitation voltage (B_u) 额定电压	V	5~15		
Insulation resistance (R _{is}) at 50Vdc 绝缘电阻	MΩ	> 5000		
Service temperature range (B _w) 工作温度	°C	-30...+70		
Safe load limit (E _L) & Breaking load(E _d) 安全承载&破坏载荷	% of E _{max}	150 & 200		
Protection class according to EN 60 529 (IEC 529) 保护等级		IP68		
Material :Measuring element 材料: 测量元件 Cable fitting 电缆配件 Cable sheath 电缆护套		Stainless or volly steel or Volly steel Stainless steel or nickel-plated brass PVC		
Maximum capacity (E _{max}) 额定载荷	t	0.5	1	2
Deflection at E _{max} (s _{nom}) ,approx 最大载荷下的变形量	mm	< 0.5	< 0.5	< 0.6
Weight(G),approx 重量	kg	1.3		
Cable 电缆: Diameter 直径: Ø6mm Length 长度	m	3.5		