

双剪切式 Double Ended Shear Beam

QS02 Load cells

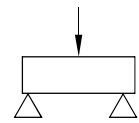
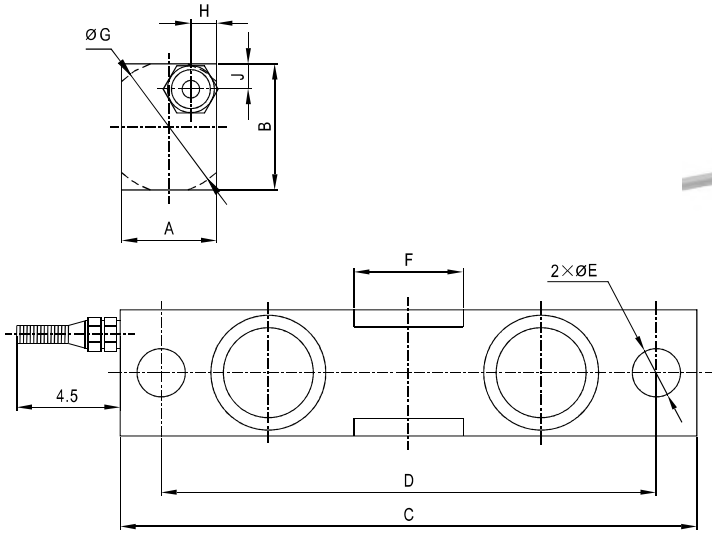

汽车衡、仓储秤等
Truck scale, warehouse scale

Emax[klb]	A	B	C	D	E	F	G	H	J
2~5	31	31	190.5	159.1	12.7	30.5	31.5	8	6.5
10~35	36.6	48.5	222	190.5	19	42	50.6	10	9.5

Specifications 技术说明 Exc+激励正 (Red,红);Exc-激励负(Black,黑);Sig+信号正(Green,绿);Sig-信号负(White,白)

Item 项目	Unit 单位	Parameter 参数						
Accuracy class to OIML R60 精度等级		C1	C2					
Maximum capacity (Emax) 额定载荷	klb	2,2.5,3,5,10,25,35						
Minimum LC verification interval (Vmin) 最小检定分度值	% of Emax	0.0200	0.0100					
Sensitivity (Cn) / Zero balance 灵敏度/零点平衡	mV/V	3.0 ± 0.005 / 0 ± 0.03						
Temperature effect on zero balance (TK0) 温度对零点影响	% of Cn/10K	±0.02						
Temperature effect on sensitivity (TKc) 温度对灵敏度影响	% of Cn/10K	±0.02						
Hysteresis error (dhy) 滞后误差	% of Cn	±0.0500	±0.0270					
Non-linearity(dlin) 非线性误差	% of Cn	±0.0500	±0.0250					
Creep(dcr) over 30 min. 蠕变及蠕变恢复	% of Cn	±0.030	±0.020					
Input (RLc) & Output resistance (Ro) 输入&输出电阻	Ω	750 ± 10 & 703 ± 2						
Nominal range of excitation voltage (Bu) 额定电压	V	5~12						
Insulation resistance (Ris) at 50Vdc 绝缘电阻	MΩ	≥5000						
Service temperature range (Btu) 工作温度	°C	-30...+70						
Safe load limit (EL) & Breaking load(Ed) 安全承载&破坏载荷	% of Emax	150 & 250						
Protection class according to EN 60 529 (IEC 529) 保护等级		IP68						
Material :Measuring element 材料: 测量元件 Cable fitting 电缆配件 Cable sheath 电缆护套		Stainless or alloy steel Stainless steel or nickel-plated brass PVC						
Maximum capacity (Emax) 额定载荷	klb	2	2.5	3	5	10	25	35
Deflection at Emax (snom) ,approx 最大载荷下的变形量	mm	0.65			0.75			
Weight(G),approx 重量	kg	1.3			2.6			
Cable 电缆: Diameter 直径: Ø6mm Length 长度	m	6			12			