

LFS01 Load cells

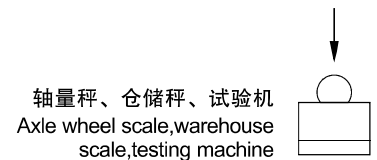
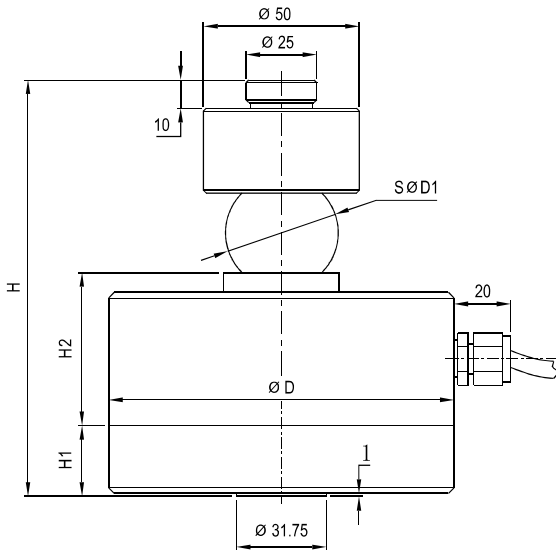

轴量秤、仓储秤、试验机
Axle wheel scale, warehouse scale, testing machine

Emax[klb]	D	D1	H1	H2	H
5,10	104.6	19.5	19.2	45.3	100
25,50,60	122	40	25	54	147
100	138	40	30	57	155

Specifications 技术说明 Exc+激励正 (Red,红);Exc-激励负(Black,黑);Sig+信号正(Green,绿);Sig-信号负(White,白)

Item 项目	Unit 单位	Parameter 参数	
Accuracy class to OIML R60 精度等级		C2	C3
Maximum capacity (Emax) 额定载荷	klb	5,10,25,50,60,100	
Minimum LC verification interval (Vmin) 最小检定分度值	% of Emax	0.02860	0.0200
Sensitivity (Cn) / Zero balance 灵敏度/零点平衡	mV/V	4.0 ± 0.005 / 0 ± 0.04	
Temperature effect on zero balance (TK0) 温度对零点影响	% of Cn/10K	±0.02	
Temperature effect on sensitivity (TKc) 温度对灵敏度影响	% of Cn/10K	±0.02	
Hysteresis error (dhy) 滞后误差	% of Cn	±0.0500	±0.0270
Non-linearity(dlin) 非线性误差	% of Cn	±0.0500	±0.0250
Creep(dcr) over 30 min. 蠕变及蠕变恢复	% of Cn	±0.030	
Input (RLc) & Output resistance (R0) 输入&输出电阻	Ω	750 ± 10 & 703 ± 2	
Nominal range of excitation voltage (Bu) 额定电压	V	5-12	
Insulation resistance (Ris) at 50Vdc 绝缘电阻	MΩ	≥5000	
Service temperature range (Btu) 工作温度	°C	-30...+70	
Safe load limit (EL) & Breaking load (Ed) 安全承载&破坏载荷	% of Emax	100 & 120	
Protection class according to En 60 529 (IEC 529) 保护等级		IP67	
Material :Measuring element 材料:测量元件 Cable fitting 电缆配件/Cable sheath 电缆护套		Alloy steel Stainless steel /PVC	

Maximum capacity (Emax) 额定载荷	klb	5	10	25	50	60	100
Deflection at Emax (snom) ,approx 最大载荷下的变形量	mm	<0.3		<0.5		<0.6	
Weight(G),approx 重量	kg	3.8		5.3		8.9	
Cable 电缆: Diameter 直径: Ø6mm Length 长度	m	6		12		12	