

HSX01

Load cells

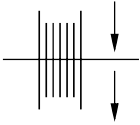
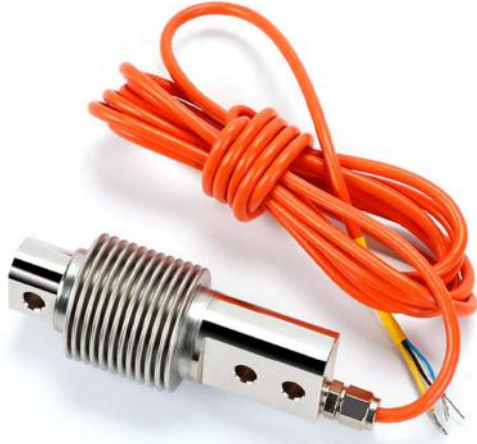

料斗秤、皮带秤、配料系统
hopper scale, belt scale, blending system

BLA:10kg...500kg

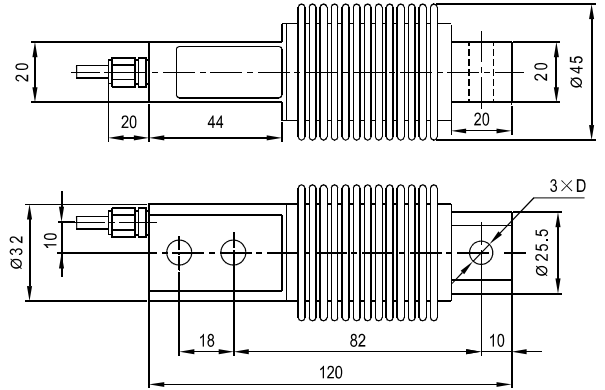

Emax[kg]	D
10,20,50,75,100,200,250	$\varnothing 8.2$
300,500	$\varnothing 10.2$

Specifications 技术说明 Exc+激励正 (Red,红);Exc-激励负(Black,黑);Sig+信号正(Green,绿);Sig-信号负(White,白)

Item 项目	Unit 单位	Parameter 参数	
		C2	C 3
Accuracy class to OIML R60 精度等级		C2	C 3
Maximum capacity (Emax) 额定载荷	kg	10,20,50,75,100,200,250,300,500,1000	
Minimum LC verification interval (Vmin) 最小检定分度值	% of Emax	0.0200	0.0100
Sensitivity (Cn) / Zero balance 灵敏度/零点平衡	mV/V	2.0 ± 0.002 / 0 ± 0.02	
Temperature effect on zero balance (TK0) 温度对零点影响	% of Cn/10K	±0.02	±0.0170
Temperature effect on sensitivity (TKc) 温度对灵敏度影响	% of Cn/10K	±0.02	±0.0170
Hysteresis error (dhy) 滞后误差	% of Cn	±0.0270	±0.0180
Non-linearity(dlin) 非线性误差	% of Cn	±0.0250	±0.0167
Creep(dcr) over 30 min. 蠕变及蠕变恢复	% of Cn	±0.0233	±0.0167
Input (RLc) & Output resistance (Ro) 输入&输出电阻	Ω	400 ± 10 & 352 ± 3	
Nominal range of excitation voltage (Bu) 额定电压	V	5~12	
Insulation resistance (Ris) at 50Vdc 绝缘电阻	M Ω	≥5000	
Service temperature range (Btu) 工作温度	°C	-30...+70	
Safe load limit (EL) & Breaking load(Ed) 安全承载&破坏载荷	% of Emax	120 & 200	
Protection class according to EN 60 529 (IEC 529) 保护等级		IP68	
Material :Measuring element 材料: 测量元件 Cable fitting 电缆配件 Cable sheath 电缆护套		Stainless or alloy steel Stainless steel or nickel-plated brass PVC	

Maximum capacity (Emax) 额定载荷	kg	10	20	50	75	100	200	250	300	500	1000
Deflection at Emax (snom) ,approx 最大载荷下的变形量	mm	0.31							0.39	0.55	
Weight(G),approx 重量	kg	0.5							1.9		
Cable 电缆: Diameter 直径: $\varnothing 5$ mm Length 长度	m	3							5		

波纹管 Bellow Type

1000kg

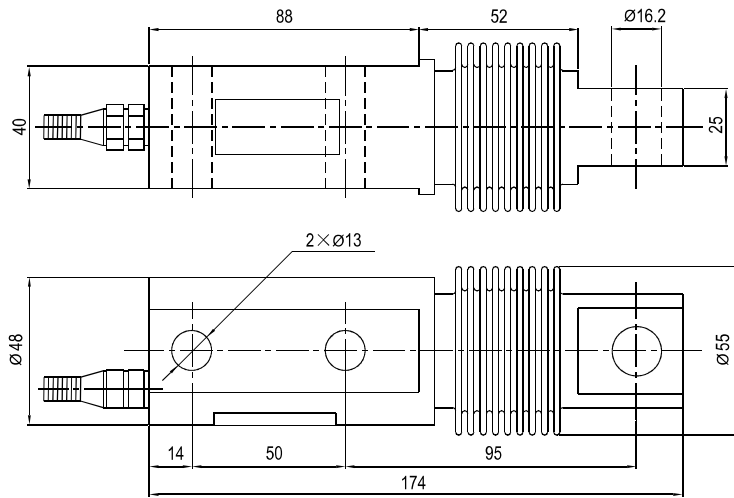

Cone and conical pan for Emax 10kg...1t.
圆锥头，圆锥面承载方式

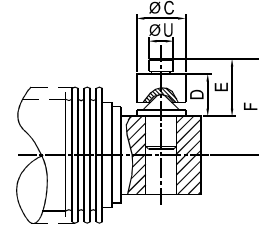

Emax	C	D	E	U	X
10~200kg	15	16	21	$8.1_{-0.05}^0$	26
300,500kg	18	24	32	$11_{-0.05}^0$	34
1t	18	24	32	$11_{-0.05}^0$	36.5

10~500kg 钢球压头承载方式:

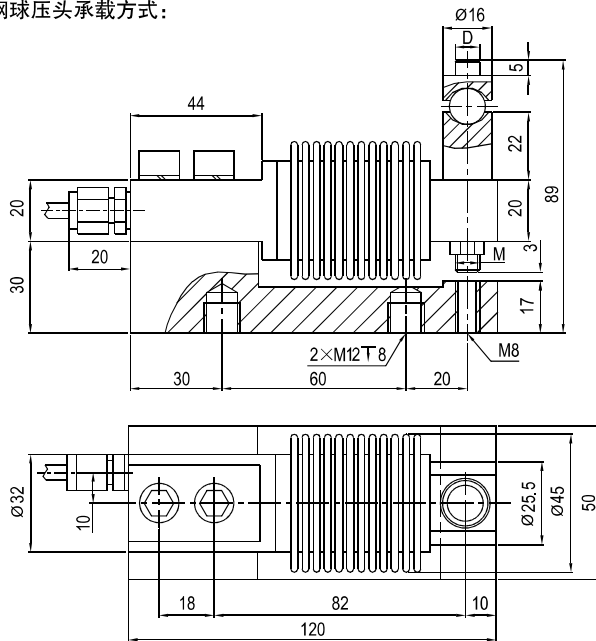

Emax[kg]	D	M
10,20,30,50,75	$\phi 8$	M8
100,200,250	$\phi 10$	M10
300,500	$\phi 10$	M10

10~500kg 拉式附件结构图

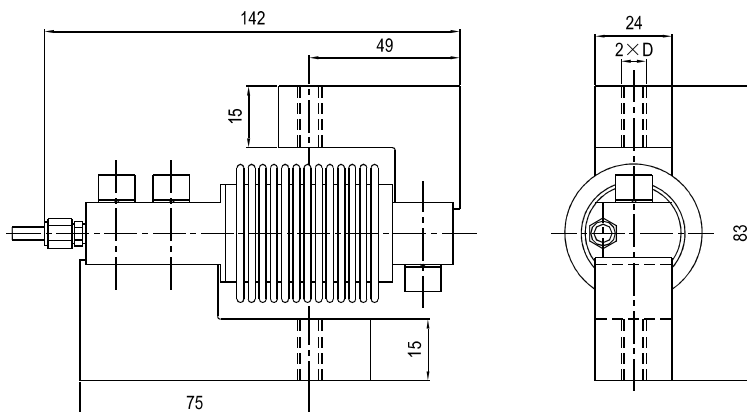

Emax[kg]	D
10,20,30,50,75	M8
100,200,250	M10
300,500	M10